



8.11-8.61

Suspended Glider

Swivel Angle Plate

Potential Equaliser Nut

Joint

Frame Joint

Mounting Adaptor for Roller

Telescope Unit

8

Additional Accessories



P. 8-02



P. 8-03



P. 8-04



P. 8-05



P. 8-07



P. 8-08



P. 8-09

Additional Accessories

Suspended Glider

The glider can be suspended in profile slot.

Material and Color: glider-PA6+GF30, black hook-zinc plated steel

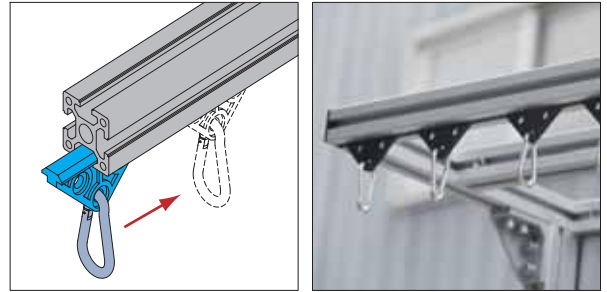

Suspended Glider-8

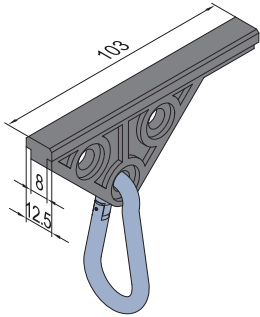

Description	Static Load (N)	Mass (g)	Part No.
Suspended Glider-8	200	48	8.11.08

Suspended Glider -10

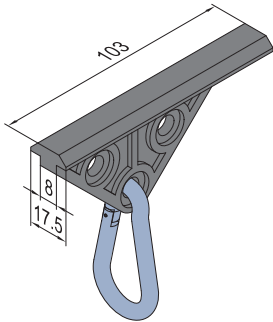

Description	Static Load (N)	Mass (g)	Part No.
Suspended Glider-10	200	48	8.11.10



Additional Accessories

Swivel Angle Plate

Infinitely variable adjusting of inclination with swivel angle.

Material and Color: steel, black electrophoresis

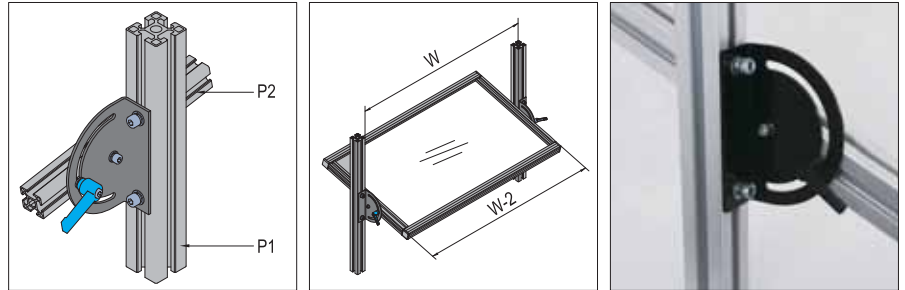

Swivel Angle Plate-PG30

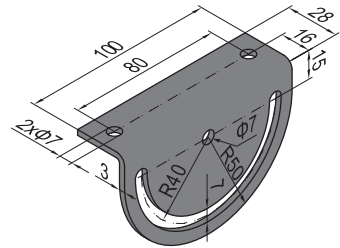

Swivel Angle Plate-PG40/45

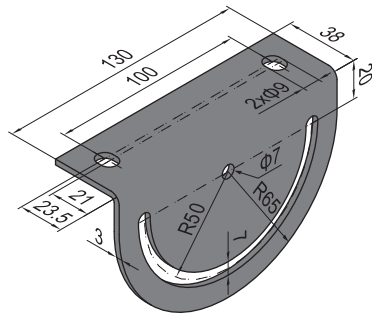

FR	FT	FV	FW	R
Fastening Set	Fastening Set	Fastening Set	Fastening Set	Fastening Set
M6x12 Adjustable Handle plastic coated, black	M6x12 Bolt zinc plated	M8x16 Bolt zinc plated	M6x16 Bolt zinc plated	M6x12 Bolt zinc plated
M6 Washer zinc plated	M6 Washer zinc plated	M8 Washer zinc plated	M6 Washer zinc plated	M6 Washer zinc plated
M6 Pre-set Nut nickel plated	M6 Pre-set Nut nickel plated	M8 T Nut nickel plated	M6 Pre-set Nut nickel plated	M6 T Nut nickel plated

Description	P1	P2	Fastening Set	Mass (g)	Part No.
Swivel Angle Plate-PG30 (pcs)				160	8.21.30
Swivel Angle Plate-PG30 (set)	PG30	PG30	1xFR+1xFT+2xR	270	8.21.30.ST
Swivel Angle Plate-PG40/45 (pcs)				288	8.21.40
Swivel Angle Plate-PG40/45-PG30 (set)	PG40/45	PG30	1xFR+1xFT+2xFV	420	8.21.40.30.ST
Swivel Angle Plate-PG40/45-PG40/45 (set)	PG40/45	PG40/45	1xFR+2xFV+1xFW	443	8.21.40.40.ST

Additional Accessories

Potential Equaliser Nut

Potential Equaliser Nut penetrates the oxide film of the profiles at the connection to conduct the static inside of the profiles and to average the potential.

Material: zinc alloy

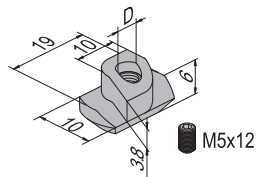
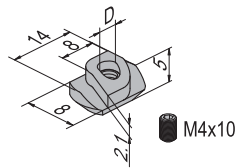

Description	D	Mass (g/pc)	Part No.
Potential Equaliser Nut-8-M4 (with top thread)	M4	3	8.22.08.M4
Potential Equaliser Nut-10-M5 (with top thread)	M5	7	8.22.10.M5

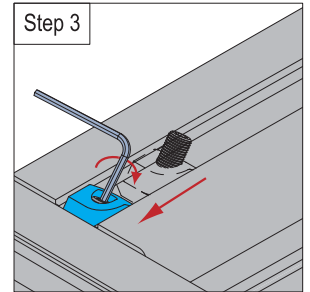
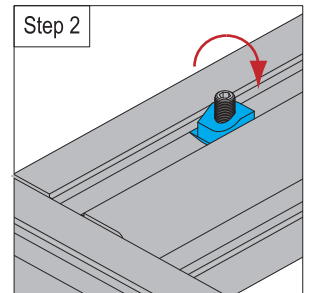
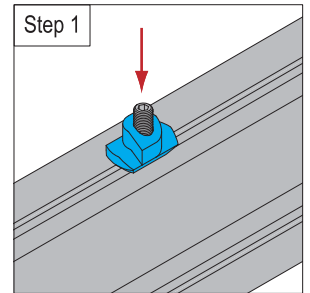
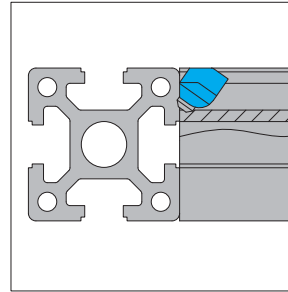

Modular Assembly System

MAS

Machine Guard System

MGS

Stair and Platform System

SPS

Tubular Framing System

TFS



Additional Accessories



Joint

To connect movable profiles.

Material: zinc plated steel



Joint-Type A

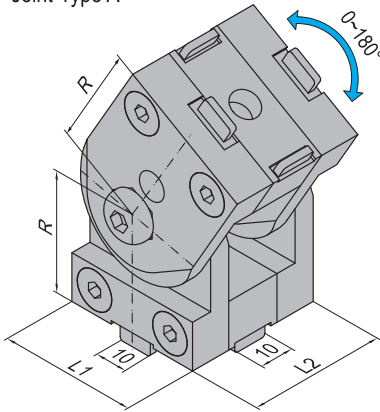



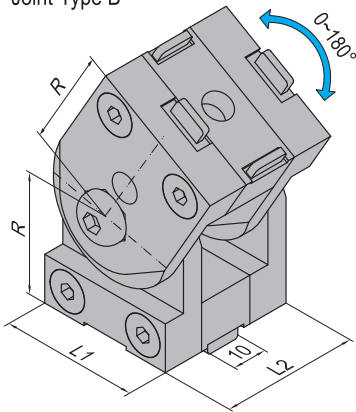

Joint-Type B

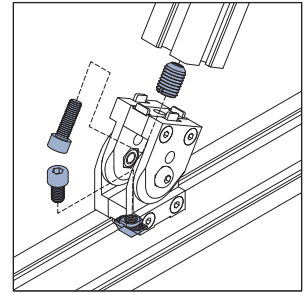
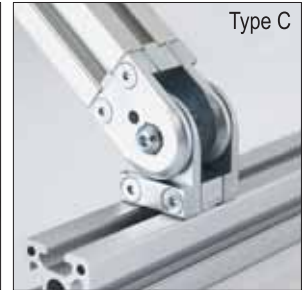
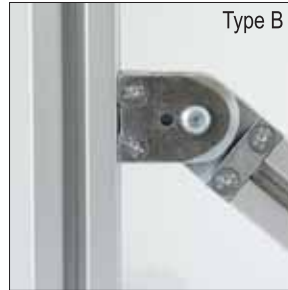
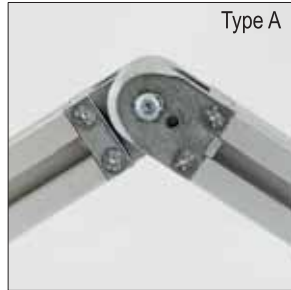
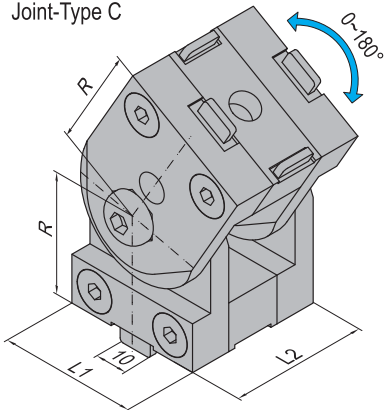

Joint-Type C



FD	Fastening Set	FX	Fastening Set
	M8x16 Bolt zinc plated		M8x20 Bolt zinc plated
	M8 T Nut nickel plated		M14-M8 Hole Reducer Bolt nickel plated

Description	L1 (mm)	L2 (mm)	R (mm)	Fastening Set	Mass (g)	Part No.
Joint-Type A-4040	40	40	35	2xFX	560	8.31.4040A
Joint-Type A-4060		60			680	8.31.4060A
Joint-Type A-4545	45	45	37.5	2xFX	650	8.31.4545A
Joint-Type A-4560		60			800	8.31.4560A
Joint-Type B-4040	40	40	35	1xFD+1xFX	575	8.31.4040B
Joint-Type B-4060		60			695	8.31.4060B
Joint-Type B-4545	45	45	37.5	1xFD+1xFX	665	8.31.4545B
Joint-Type B-4560		60			815	8.31.4560B
Joint-Type C-4040	40	40	35	1xFD+1xFX	575	8.31.4040C
Joint-Type C-4060		60			695	8.31.4060C
Joint-Type C-4545	45	45	37.5	1xFD+1xFX	665	8.31.4545C
Joint-Type C-4560		60			815	8.31.4560C



Additional Accessories



Joint

To connect movable profiles.

Material: zinc alloy



Joint-Type A

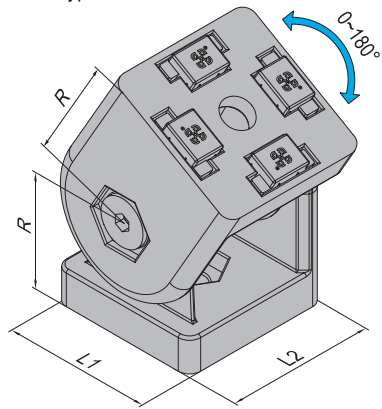

Joint-Type B

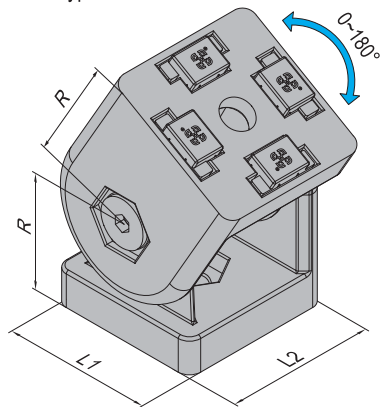

Joint-Type C

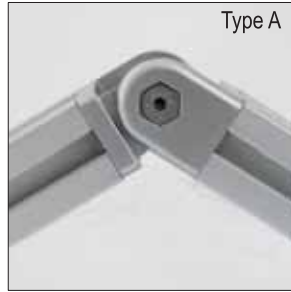
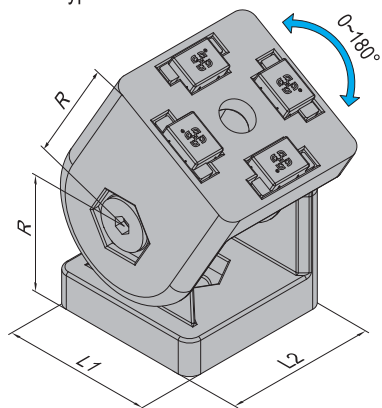

Type A



Type B

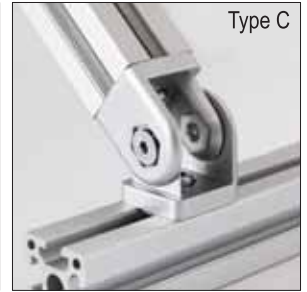

Type C



RH

Note: Ratchet handle (part number RH) is an optional accessory for all three connection types-type A, B and C.

FS	FO	FU	FX
Fastening Set	Fastening Set	Fastening Set	Fastening Set
 M6x10 Bolt zinc plated	 M6x16 Bolt zinc plated	 M8x12 Bolt zinc plated	 M8x20 Bolt zinc plated
 M6 T Nut nickel plated	 M12-M6 Hole Reducer Bolt nickel plated	 M8 T Nut nickel plated	 M14-M8 Hole Reducer Bolt nickel plated

Description	L1 (mm)	L2 (mm)	R (mm)	Fastening Set	Mass (g)	Part No.
Joint-Type A-3030	30	30	22.5	2xFO	181	8.32.3030A
Joint-Type A-3030-RH					211	8.32.3030A.RH
Joint-Type A-4040	40	40	30	2xFX	388	8.32.4040A
Joint-Type A-4040-RH					447	8.32.4040A.RH
Joint-Type B-3030	30	30	22.5	1xFS+1xFO	167	8.32.3030B
Joint-Type B-3030-RH					206	8.32.3030B.RH
Joint-Type B-4040	40	40	30	1xFU+1xFX	366	8.32.4040B
Joint-Type B-4040-RH					437	8.32.4040B.RH
Joint-Type C-3030	30	30	22.5	1xFS+1xFO	167	8.32.3030C
Joint-Type C-3030-RH					206	8.32.3030C.RH
Joint-Type C-4040	40	40	30	1xFU+1xFX	366	8.32.4040C
Joint-Type C-4040-RH					437	8.32.4040C.RH



Additional Accessories



When the profile frame is with big span and there is slight bending caused by self load, the frame joint shall be used with special connectors for cross connection to enhance the stability of the frame.

Material: aluminium, anodized (cutting end not anodized).

End cap: black ABS

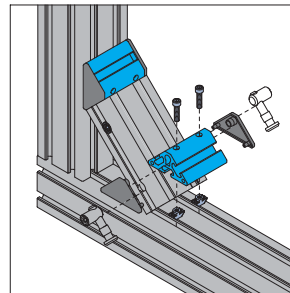
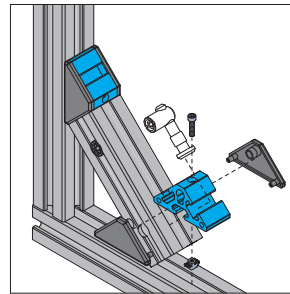
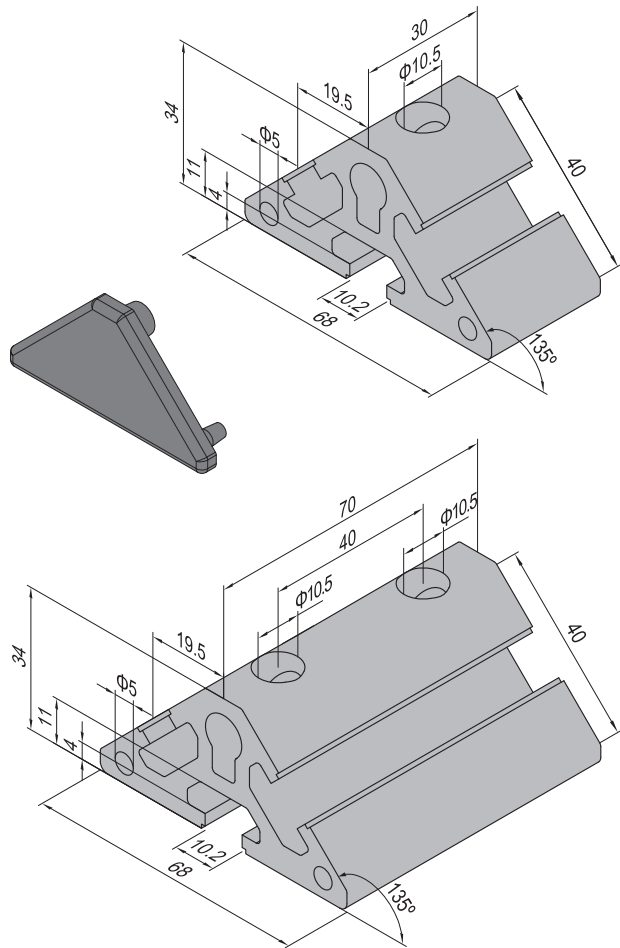

Description	Fastening Set	End Cap	Mass (g)	Part No.
PG40-4040	1xCB	2	95	8.41.4040
PG40-4080	2xCB		192	8.41.4080

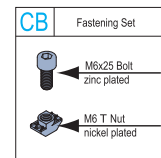

Note: Anchor Connector to be ordered separately refer to P. 3-03 for more detail.



Additional Accessories

Mounting Adaptor for Roller

Special connector for quick roller installation.

Material: Adaptor-steel, zinc plated End cap: black PA6



Mounting Adaptor for Roller-A

End Cap

End Cap

Left

Right

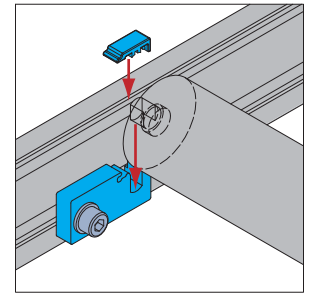
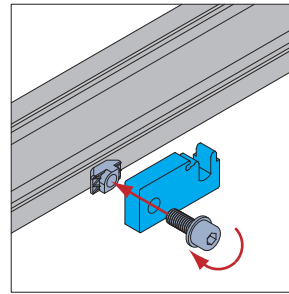
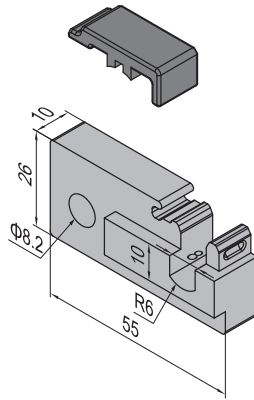
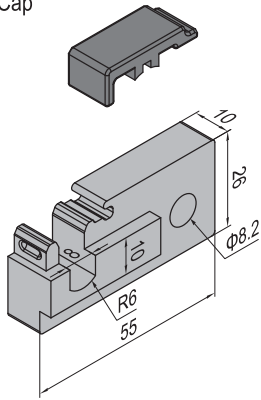

Mounting Adaptor for Roller-B

End Cap

End Cap

Left

Right

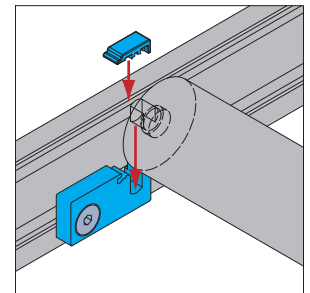
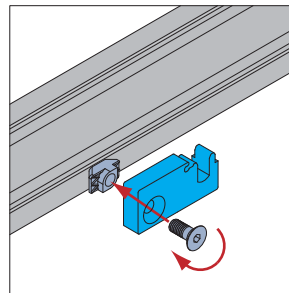
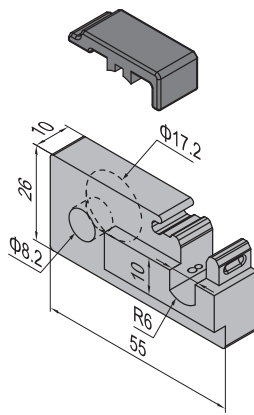
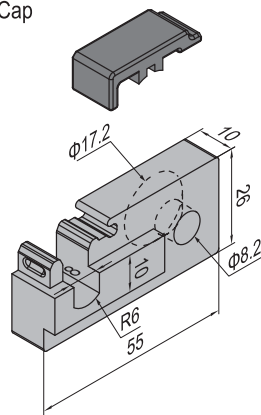

Description	Fastening Set	End Cap	Mass (g)	Part No.
Mounting Adaptor for Roller-A-Left+Right (pcs)		2	200	8.51.01A
Mounting Adaptor for Roller-A-Left+Right (set)	2xD		242	8.51.01A.ST
Mounting Adaptor for Roller-B-Left+Right (pcs)		2	194	8.51.01B
Mounting Adaptor for Roller-B-Left+Right (set)	2xFQ		226	8.51.01B.ST

D	Fastening Set	FQ	Fastening Set
	M8x20 Bolt zinc plated		M8x20 Bolt zinc plated
	M8 Washer zinc plated		M8 T Nut nickel plated
	M8 T Nut nickel plated		



Additional Accessories

Telescope Unit

Telescope Unit are composed of strut profile, telescopic profile and connecting elements, the stroke of telescope unit is 50-500mm.



Telescope Unit-3030

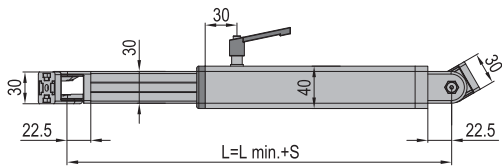

Telescope Unit-3040

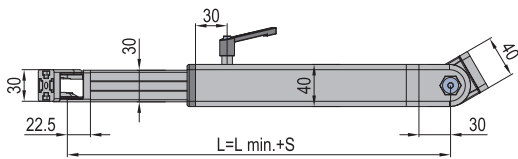

Description	Stroke S(mm)	L min. (mm)	Mass (kg)	Part No.
Telescope Unit-3030 (set)	50≤S≤200	369	1.23	8.61.40.3030.01.ST
	200<S≤350	519	1.43	8.61.40.3030.02.ST
	350<S≤500	669	1.94	8.61.40.3030.03.ST
Telescope Unit-3040 (set)	50≤S≤200	377	1.42	8.61.40.3040.01.ST
	200<S≤350	527	1.62	8.61.40.3040.02.ST
	350<S≤500	677	2.13	8.61.40.3040.03.ST

Note: Offer per set. If there is any special requirement on the stroke, please contact with us.

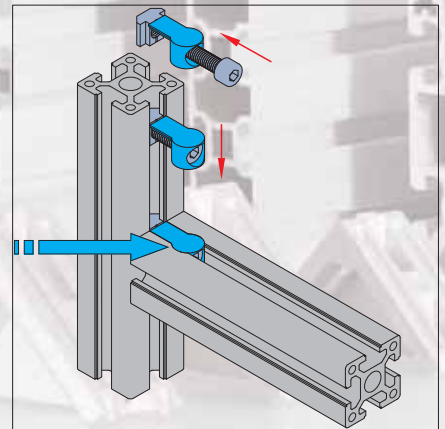
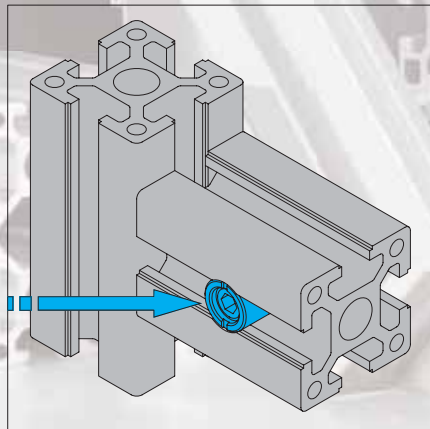
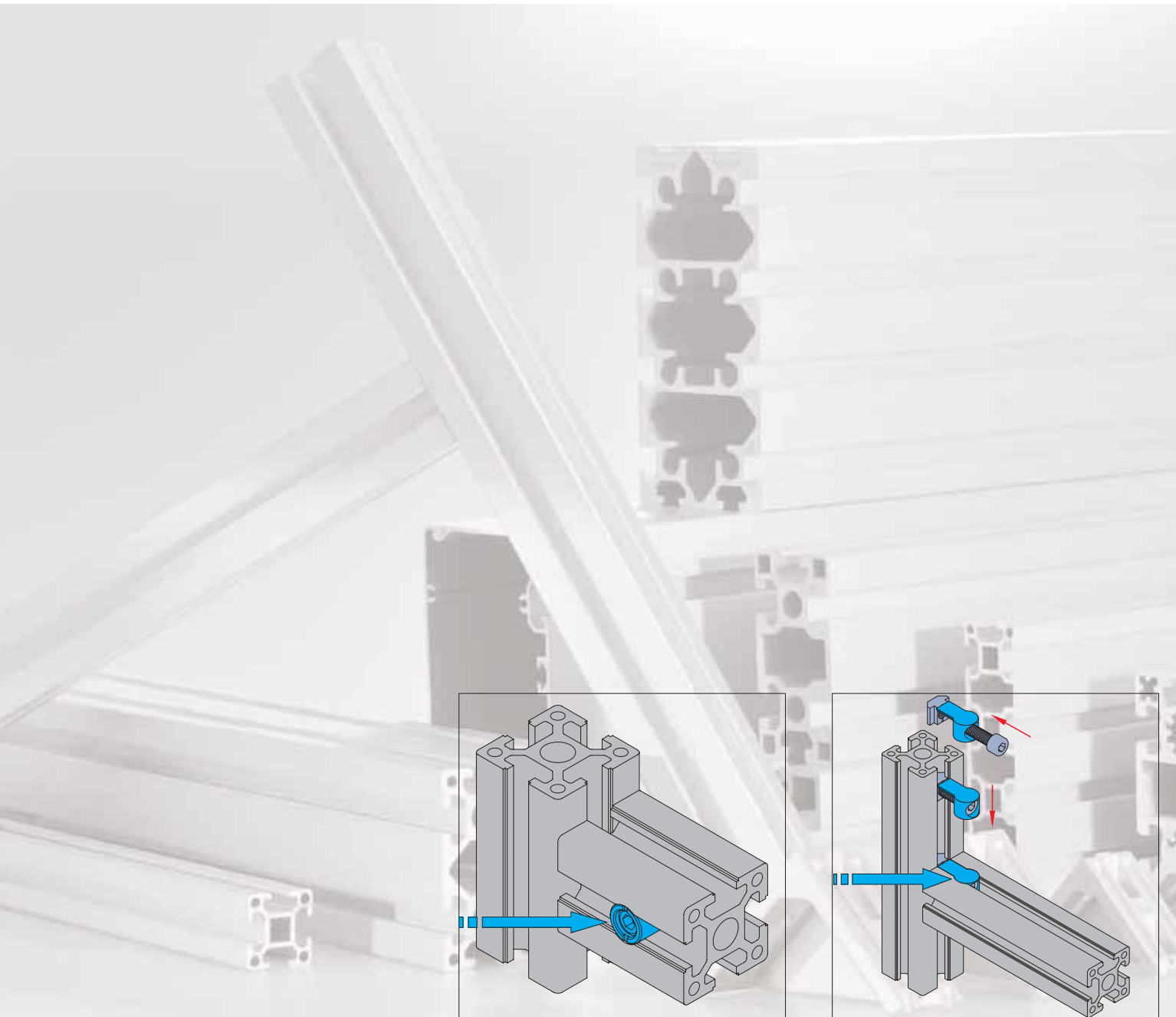

Profile Machining Code

Modular Assembly System

MAS

Machine Guard System

MGS

Stair and Platform System







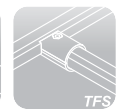



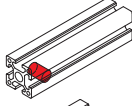
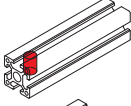
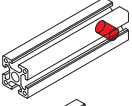
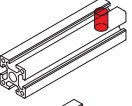

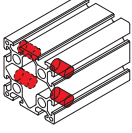
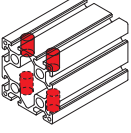
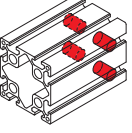
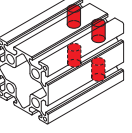
SPS

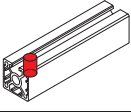
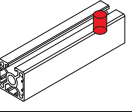
Tubular Framing System

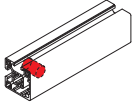
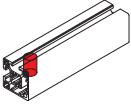
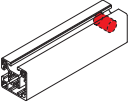
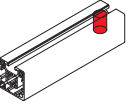
TFS

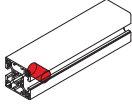
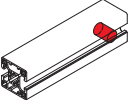

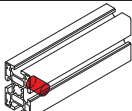
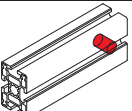
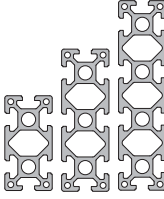
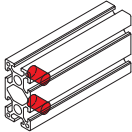
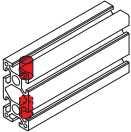
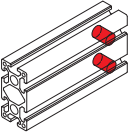
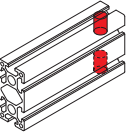
Dowel bore

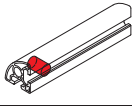
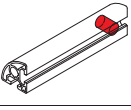
Classification		Dowel bore			
		Left		Right	
		Horizontal	Vertical	Horizontal	Vertical
Code		LDH	LDV	RDH	RDV
Square					
					
		—		—	
					
			—		—
Rectangle			—		—
					
Arc			—		—

Modular Assembly System

MAS

Machine Guard System

MGS

Stair and Platform System

SPS

Tubular Framing System

TFS





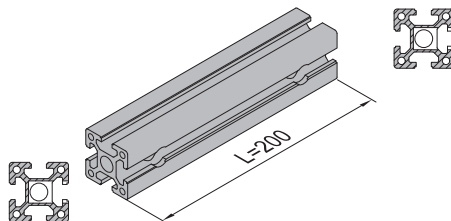



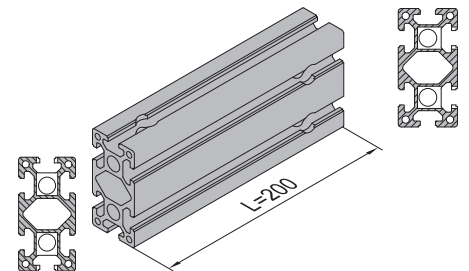



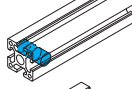
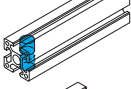
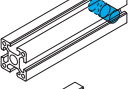
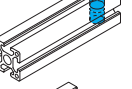

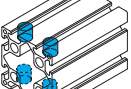
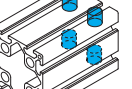

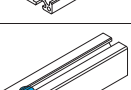
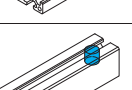



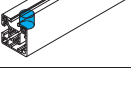

Example A: 1. 11. 40.040040.04H-200-LDH/RDH

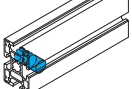
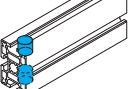
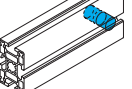

Example B: 1. 11. 40.040080.08H-200-LDV/RDH

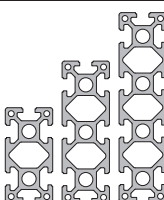

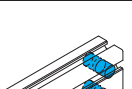
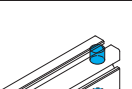
Inner connector bore

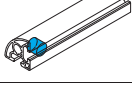
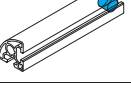
Classification		Inner connector bore			
		Left		Right	
		Horizontal	Vertical	Horizontal	Vertical
Code		LIH	LIV	RIH	RIV
Square					
		—		—	
		—		—	
			—		—
					
Rectangle					
					
Arc			—		—

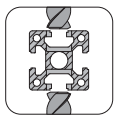



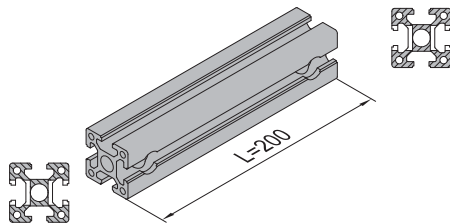



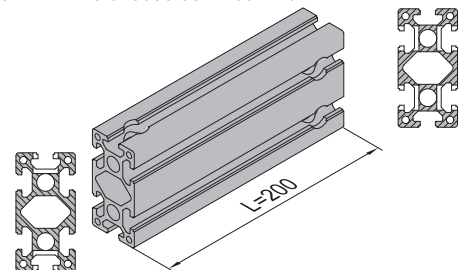

Example A: 1. 11. 40.040040.04H-200-LIH/RIH

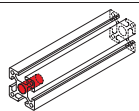
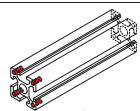
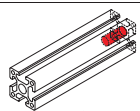
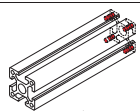
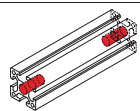
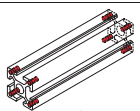

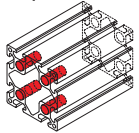
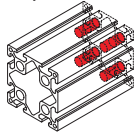
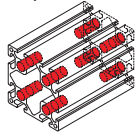
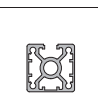
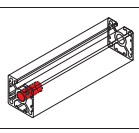
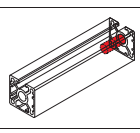
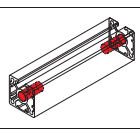
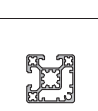
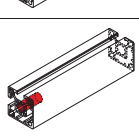
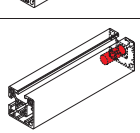
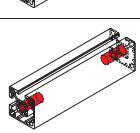
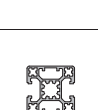
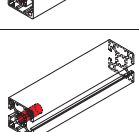
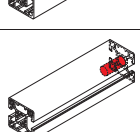
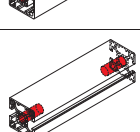
Example B: 1. 11. 40.040080.08H-200-LIV/RIH

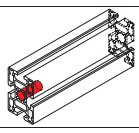
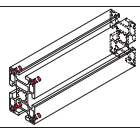
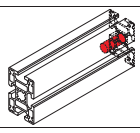
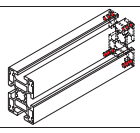
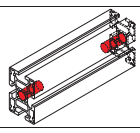
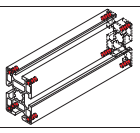

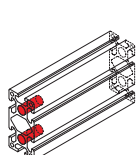
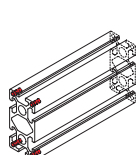
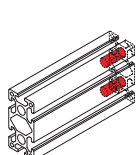
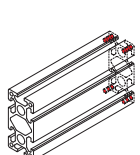
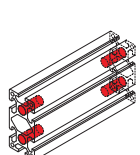
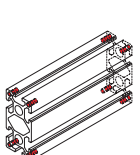
Screw thread bore

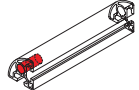
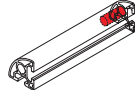
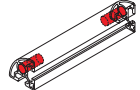
Classification		Screw thread bore					
		Left		Right		Left+ Right	
Code		LSP	LMP	RSP	RMP	WSP	WMP
Square							
			---		---		---
			---		---		---
			---		---		---
			---		---		---
Rectangle							
							
Arc			---		---		---

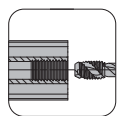

Standard: depth=22mm

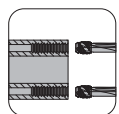

Standard: depth=22mm

Example A:

1. 11. 40.040040.04H-200-LSP

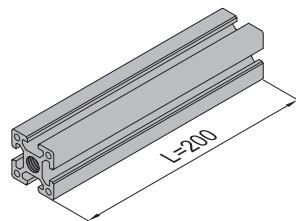

Example B:

1. 11. 40.040080.08H-200-WSP

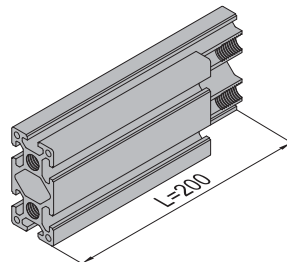

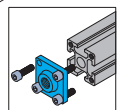
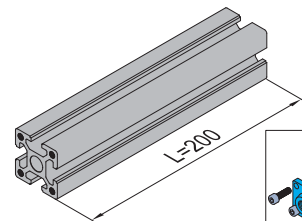

Example C:

1.11.40.040040.04H-200-LMP

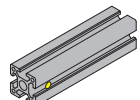
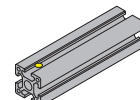
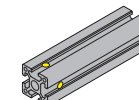
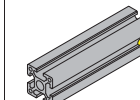
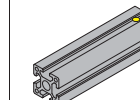
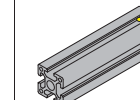
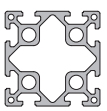
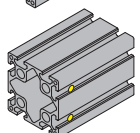
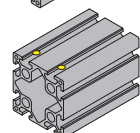
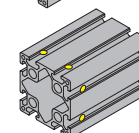
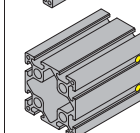
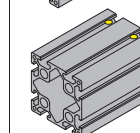
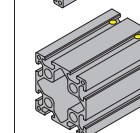
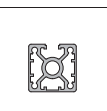
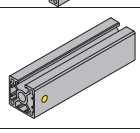
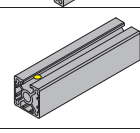
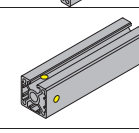
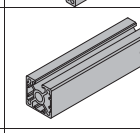
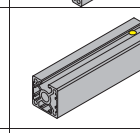
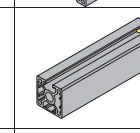
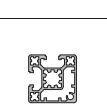
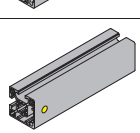
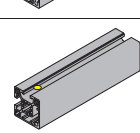
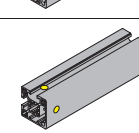
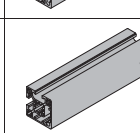
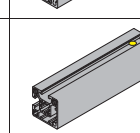
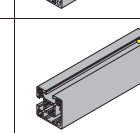
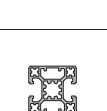
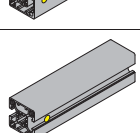
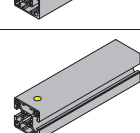
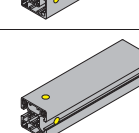
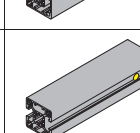
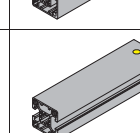
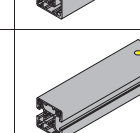

Cross bore

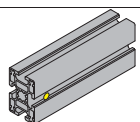
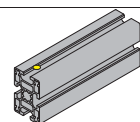
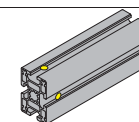
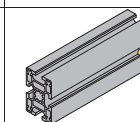
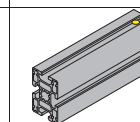
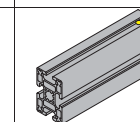
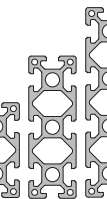
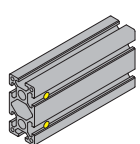
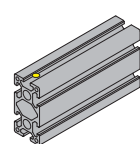
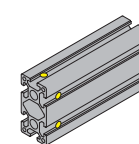
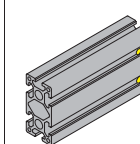
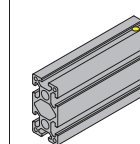
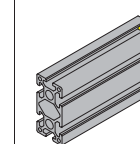
Classification		Cross bore					
		Left			Right		
Code	Image	Horizontal	Vertical	H+V	Horizontal	Vertical	H+V
		LCH	LCV	LCP	RCH	RCV	RCP
Square							
							
							
							
							
Rectangle							
							

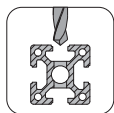

Specified crossing bore code



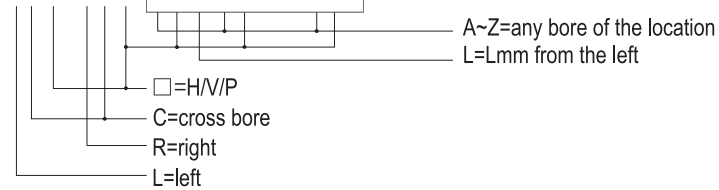



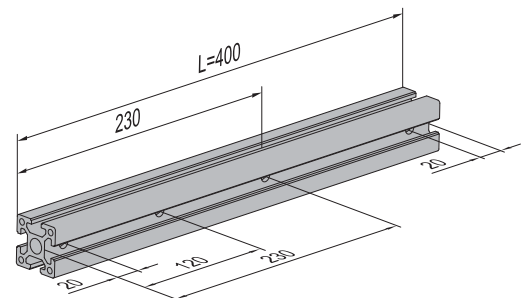

LC□/□**RC**□-**A**□**L**-**B**□**L**-...**Z**□**L**

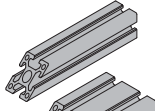
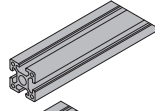
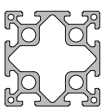
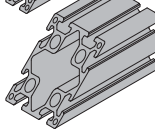
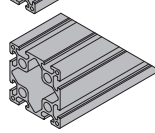

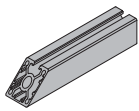
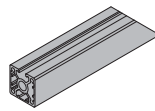
Example: 1. 11. 40.040040.04H-400-LCH/RCH-AH120-BP230

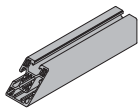
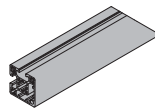

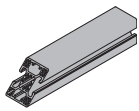
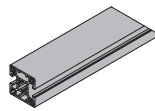
Angle cut

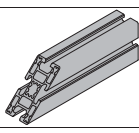
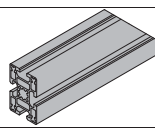
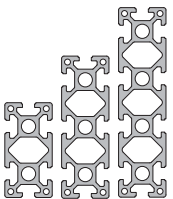
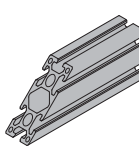
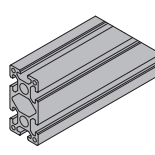
Classification		Angle cut	
		Left	Right
Code		LCT(LAT,LBT,LDT)	RCT(RAT,RBT,RDT)
Square			
			
			
			
			
Rectangle			
			

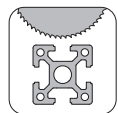

Specified cutting angle code

L□Tα:

- α=30°/45°/60°
- T=angle cut
- =A/B/C/D
- L=left

R□Tα:

- α=30°/45°/60°
- T=angle cut
- =A/B/C/D
- R=right

Example: 1. 11. 40. 040060.06H-300-LDT45/RDT45

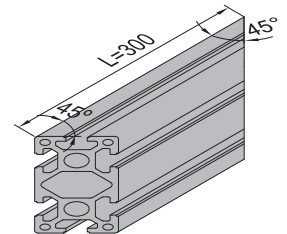

□=A

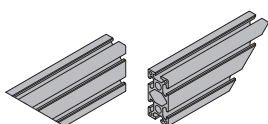

□=B

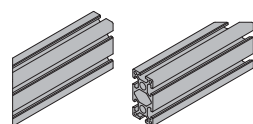

□=C

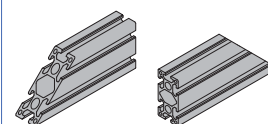

□=D

